



# A9 Monsoon™

Multi-Purpose Regenerative Air Sweeper



\*Sweepers shown with optional equipment

## NON-STRUCTURAL BEST MANAGEMENT PRACTICES:



VACUUM AND BRUSH  
REMOVAL OF DEBRIS

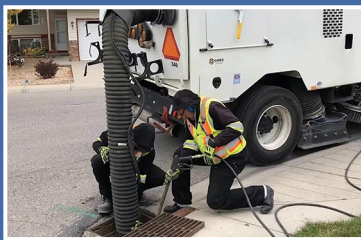

CATCH BASIN CLEANING  
OF DEBRIS AND POLLUTANTS



POWERFUL MAGNET TO  
COLLECT FERROUS MATERIAL

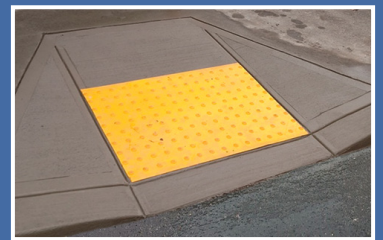

HIGH PRESSURE WASHDOWN  
TO CLEAN ADA RAMPS

Your Schwarze Dealer.

A FAMILY COMPANY SINCE 1967



**WE KNOW CLEAN** 

800.626.7835  [BORTEKINDUSTRIES.COM](http://BORTEKINDUSTRIES.COM)

Street sweeping is a best management practice (BMP) that can serve the entire community. With catch basin cleaner equipped you can go to work immediately after purchase as opposed to structural BMPs like storm ponds that only serve a dedicated area and require engineering and construction. This makes sweeping the most cost effective BMP per impervious acre treated [King, Hagen, 2011]



# A9 Monsoon™

## 9.6 Cubic Yard Multi-Purpose Regenerative Air Sweeper

Effective January of 2017, the EPA Final MS4 General Permit Remand Rule requires “clear, specific, and measurable permitting” conditions for measuring BMP implementation. In addition, MS4s that discharge to impaired waters must develop a total maximum discharge limit (TMDL) strategy and plan to reduce sediment, phosphorous, and nitrogen discharged into protected watersheds. The new ruling also requires greater public participation in the NPDES permitting process.

Schwarze regenerative air technology makes use of both positive pressure and vacuum airflow, this maintains the compressed air in a sealed loop and is not returned to the atmosphere like traditional vacuum sweepers.

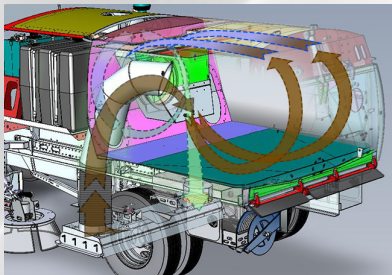

### Regenerative Air Technology

Regenerative air sweepers generally only need 100KW to do the same amount of work as pure vacuum sweepers with 200KW.

The blast and recovery cycle continues indefinitely with no air leakage.

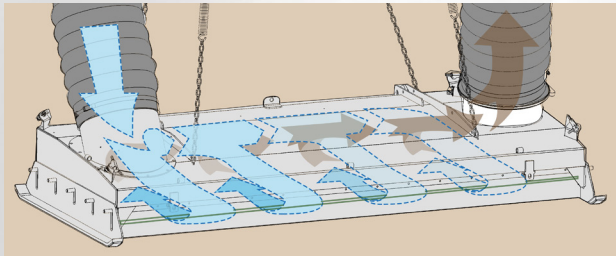

Pressurized air is forced across an “air knife” approximately 2.5 meters wide across the sweeping head. This scrapes the roadway surface with a sheet of pressurized air, lifting dirt and debris off the pavement.

Schwarze and its global dealer network understands your challenges and helps stormwater managers meet these conditions while being good stewards of taxpayer dollars.



We make sure the correct features are included to optimize municipal sweeping programs such as:

- Reducing trips to the landfill so you can continue working and keep earning credits.
- Catch basin suction hoses with high pressure water.
- Telematics for integration with your GIS system to document work for compliance and show citizens that their streets and catch basins have been cleaned.

# A9 Monsoon™ Multi-Purpose Regenerative Air Sweeper



Up to 144" Sweep Width

90" Pickup Head



Large Saw-Tooth Increased Hopper Screen Design



Powerful Height Adjustable, Cab Controlled Self-Dumping Front Magnet

High Pressure Water Spraygun



CAN-Bus Control Panel with Backlit Switches, Text and Icons



44" Recessed Gutter Brooms with Shielded Broom Motor



Heavy Duty Catch Basin Vacuum Hose with Hand Controls

Backup Camera

Bolt-On Tubes

Sweepers are also a great traveling billboard. We work with your program to design wraps that promote "clean streets, clean stream" initiatives, or our popular "only rain in the storm drain" promotion.



Sweeper shown with optional equipment.



Additional Available Regenerative Air Sweepers:



\*Ask us about our optional:



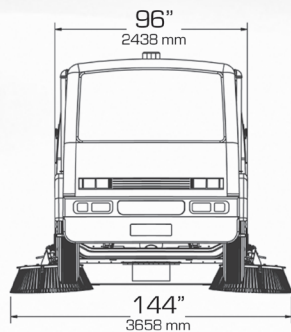
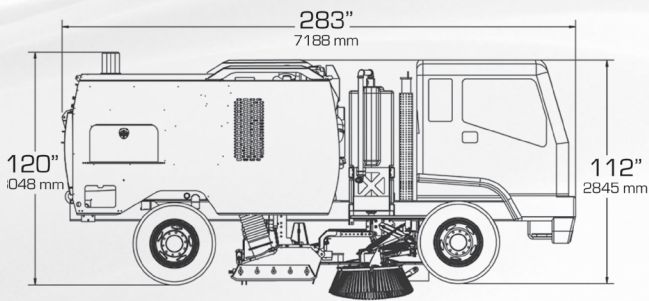

\*TYPICAL MEASUREMENTS SHOWN, EXACT DIMENSIONS DEPENDING ON OPTIONS AND TRUCK MANUFACTURER

### SWEEPING PATH

Pickup head only	90 in [2286 mm]
Head and 1 broom	117 in [2972 mm]
Head and 2 brooms	144 in [3658 mm]

### CHASSIS

Mounts on various chassis to meet requirements

### SWEEPER BODY

Construction	Welded 10-gauge stainless steel plate
Safety props	Lift spacers

### STANDARD ENGINE

Model/type	4045T in-line 4 cylinder
Aspiration	Tier 4 Final turbo-charged diesel
Manufacturer	John Deere
Displacement	275 cu. in. [4.5 L]
Brake horsepower	134 hp [100 kw] @ 2400 rpm
Torque	398 ft lb [540 Nm] @1600 rpm
Air cleaner	Centrifugal precleaner; dry type with safety element and restriction indicator
Oil filter	Full-flow/spin-on
Stroke	5 in [127 mm]
Bore	4.20 in [106 mm]
Compression ratio	19 to 1
Safety shutdown	Three-point automatic
Throttle control	Electronic

### SWEEPER ELECTRICAL SYSTEM

Voltage	12 V
Engine alternator	90 amp

### DUST CONTROL SYSTEM

Type	Run dry diaphragm
Capacity	250 gallon [946 L]
Tank construction	Polyethylene filter; 50 mesh; cleanable
Fill diameter	2.5 in [63.5 mm]
Fill hose	25 ft [7620 mm]
Controls	Electric; in-cab
Nozzles	2 on each broom; 5 around suction head; 2 inside suction nozzle; 2 on front axle; 4 inside hopper
Water level gauge	In-cab

### INSTRUMENTATION

Auxiliary engine	Flat panel display; tachometer; hourmeter; voltmeter; temperature gauge; oil pressure gauge; warning icons
------------------	--

### FAN SYSTEM

Type	Closed-face radial
Drive	Direct via 5 groove; banded power belt
Construction	Hardox steel
Balance	1.5 grams on 2 sides
Diameter	32.75 in [832 mm]
Housing lining	Bolt-in corded rubber
Mounting	2 regreaseable sealed bearings
Vacuum enhancer	For heavy/light material; in-cab indicator

### PICKUP HEAD

Type	Dual chambered full-width blast orifice
Operating direction	Forward and reverse
Suspension	Adjustable spring balanced
Length	90 in [2286 mm]
Pressure hose diam	14 in [355.6 mm]
Suction hose diam	14 in [355.6 mm]
Hose construction	3/8" [9.5 mm] wire-reinforced molded rubber
Head area	3240 sq in [20903 sq cm]
Controls	Hydraulic raise and lower
Skids	Double wide tungsten carbide
Construction	Abrasion-resistant steel inlet and outlet transitions.

### SIDE BROOMS

Type	Vertical steel digger
Location	Right; left; forward of pickup head
Diameter	44 in [1118 mm]
Drive	Hydraulic
Suspension	Torque-sensing spring
Wear adjustment	Automatic
Pressure	Manual
Speed	Variable; non-reversing
Segments	5 each side; disposable
Tilt angle adjustment	In-cab controls

### DEBRIS HOPPER

Volumetric capacity	9.6 cu yd [7.3 cu m]
Usable Capacity	8.0 cu yd [6.1 cu m]
Dump angle	53 degrees
Floor angle	3 degrees
Lifting	Twin hydraulic cylinders
Hopper dump door	hydraulic open, close, lock
Inspection doors	1 on each side, pressure vessel lock
Hopper dump height	33 in [838 mm]
Screens	Sawtooth drop down

### HYDRAULIC SYSTEM

Type	Dual output 2 section
Pump capacity	8 gpm @ 1800 rpm [30 lpm] per section for 16 gpm total
Drive	Direct gear
Maximum pressure	2750 psi [190 bar]
Reservoir	25 gal [94 L]
Filter	10 micron; spin on
Protection	Pressure relief valve
Controls	Electro-hydraulic

### AUXILIARY HYDRAULIC SYSTEM

Type	Gear type; driven by electric motor
Function	Lower hopper; open/close hopper door; raise brooms and pickup head

### PAINT

One coat of sealer/primer and two coats of in standard white color.	
Paint	White; Sherwin Williams Genesis G2 #100268977

### OPTIONAL SWEEPER EQUIPMENT

- Special Paint
- Front Mounted Magnet Bar
- Amber Beacon
- Strobe Light Kit
- Arrowboard Kit
- Additional Flood Lights
- Hopper Hand Hose
- Remote Drop Down Screens
- Hopper Dump Assist Shaker
- 12-volt Auxiliary Hydraulic System
- Dual Steeling and Controls
- Extra Water
- High Pressure Front Spraybar
- High Pressure Wash Dow
- Side Air Blast Head
- Hopper Deluge
- Head Drain
- Dual Outside Hopper Controls
- Lifetime Hopper Warranty
- Short Wheelbase Chassis

Note: Design and specifications subject to change without notice.

Sourcewell

Awarded Contract

Contract # 093021-SWZ

**HGACBuy**  
THE SMART PURCHASING SOLUTION



© 2022 Schwarze Industries  
1055 Jordan Road  
Huntsville, AL 35811  
800.879.7933  
An Alamo-Group Company