



The People You Know. The Products You Trust.



# A8 Twister™

6 Cubic Yard High Dump Regenerative Air Sweeper

\*Sweeper shown with optional equipment

A FAMILY COMPANY SINCE 1967



WE KNOW CLEAN®

800.626.7835 BORTEKINDUSTRIES.COM

- 2' to 12' Dump Height
- Extra Long Hand Hose Stroke Boom
- Full Function Display Control Panel
- Standard Tier 4 Final Engine

Quality	Performance	Public Safety	Value	Customer Support

800.879.7933

www.schwarze.com

↑ 24" to 144" Dump Height

# A8 Twister™

## 6.0 Cubic Yard High Dump Regenerative Air Sweeper

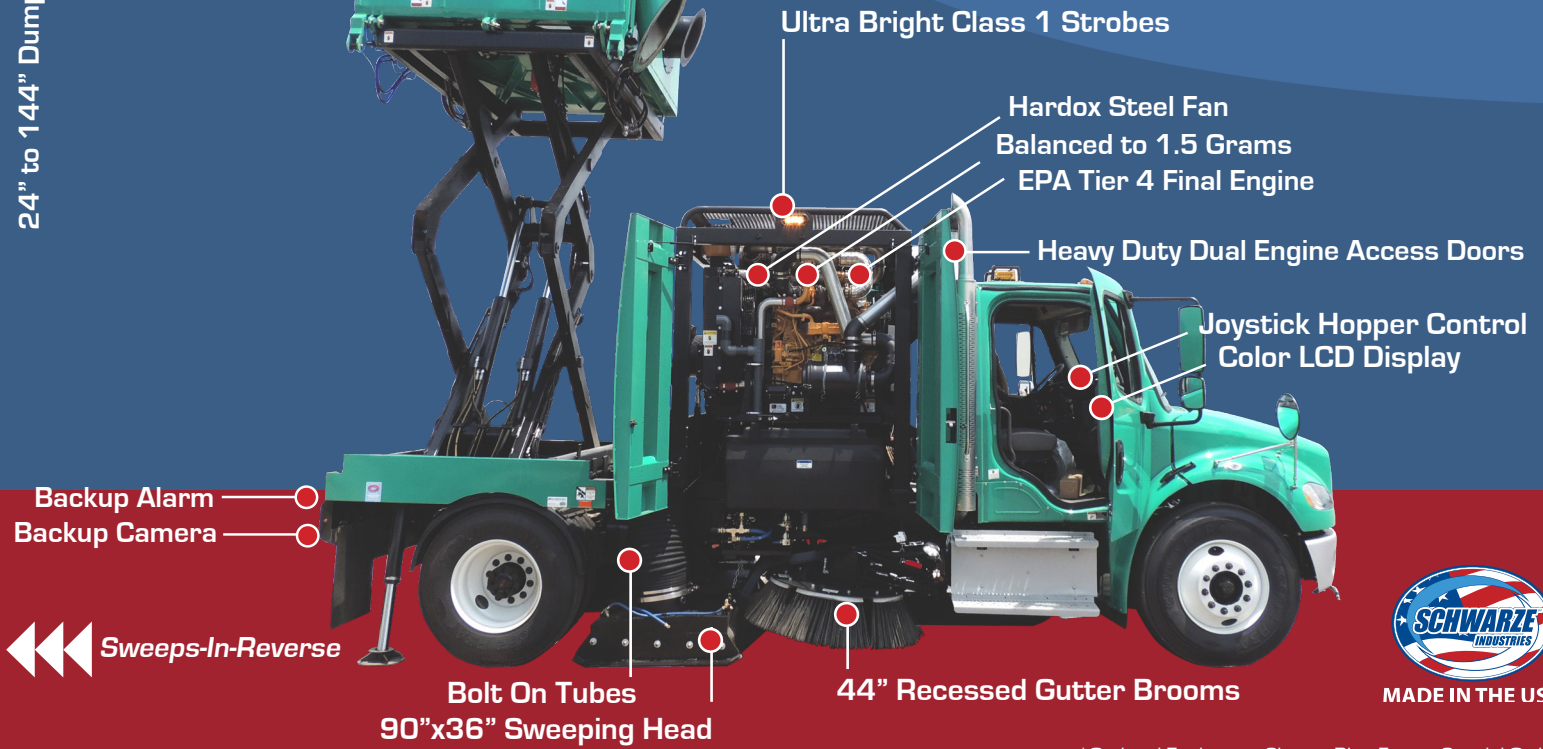

\*Optional Equipment Shown, Blue Frame Special Order

Shielded broom motor reduces entanglement of strings & twine.

Easy to use color coded switches with Onboard Diagnostics



### MUST HAVE OPTIONS

#### ADDITIONAL WATER

Add a 600 gallon tank on longer chassis,

#### EXTENDED REACH

Add broom tilt and Gutterbroom Extension Override (GEO™)

#### EASE OF APPLICATION

Add an 8" hand hose extension for hard to get to reach applications.

#### FEEL THE POWER

Add in-cab down pressure broom control.

Quick release clamps for easy rotation and replacement of hoses.

Extra long stroke boom for efficient use of hand hose.

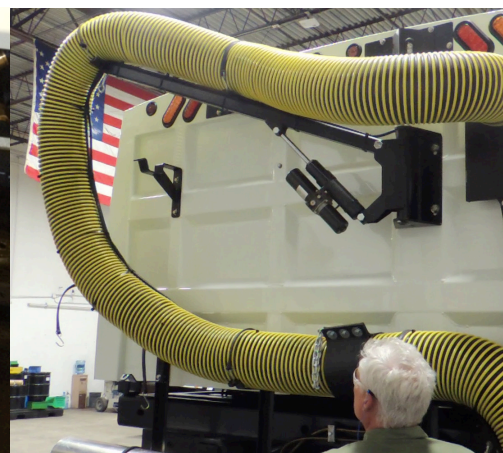
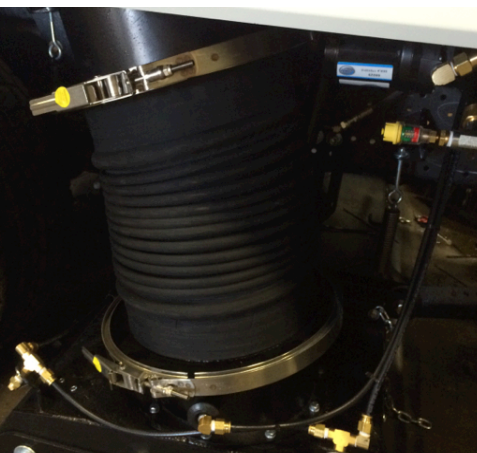

Available With  
**CUMMINS**  
*Tier 4*  
Sweeper Engine

## VALUE

We are dedicated to satisfying our customers by providing the most advanced training for their specific needs. Our training programs are designed to help operators of all skill levels learn the best operating practices for their Schwarze equipment.



## PERFORMANCE

There is a lot riding on creating solutions that are suited to the particular needs of different industry applications. Innovation often involves high technology, but doesn't always have to be. Some of our best ideas have been simple, based on a clear and deep understanding of our customers' working lives.



## QUALITY

In a Schwarze product, end user concerns like fuel efficiency, serviceability, durability, purchase cost, service cost, etc. are all taken into account. We also consider the needs and strive for ease of use and application optimization. It should be obvious, because when it comes to cost of ownership, quality pays.



## PUBLIC SAFETY

No other name speaks safety louder than Schwarze. Protecting operators, those around them, and minimizing our environmental impact are traditional values that continue to shape our product design philosophy.



## CUSTOMER SUPPORT

Being a Schwarze customer means having a complete set of services at your fingertips. Schwarze can offer you a long-term relationship, protect your revenue and provide a full range of customer solutions, delivered by passionate people. At Schwarze, we don't see effective service and support just as an added value to your purchase, but as an integral part of it.



Also Available from Schwarze Industries, Inc:



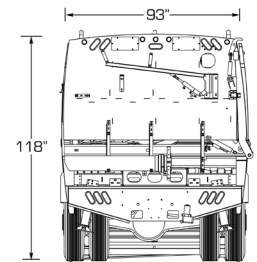
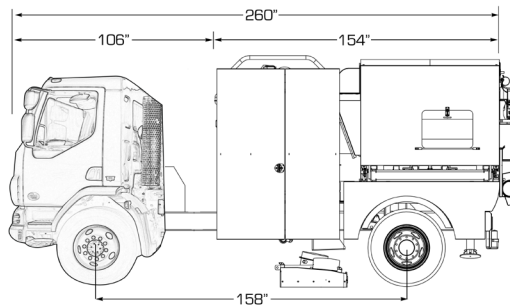
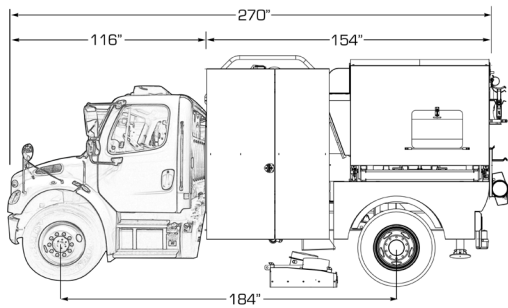

\*TYPICAL MEASUREMENTS SHOWN, EXACT DIMENSIONS DEPENDING ON OPTIONS AND TRUCK MANUFACTURER

### SWEEPING PATH

Pickup head only	90 in (2286 mm)
Pickup head and one side broom	117 in (2972 mm)
Pickup head and two side brooms	144 in (3658 mm)

### CHASSIS

Mounts on various chassis to meet requirements

### SWEEPER BODY

Construction	Welded 10-gauge stainless steel plate
Safety props	Lift spacers

### INSTRUMENTATION

Auxiliary engine	Flat panel display; tachometer; hourmeter; voltmeter; temperature gauge; oil pressure gauge; warning icons
------------------	--

### AUXILIARY ENGINE

Model/type	4045T in-line 4 cylinder
Aspiration	Tier 4 Final turbo-charged diesel
Manufacturer	John Deere
Displacement	275 cu in (4.5 L)
Brake horsepower	134 hp (100 kw) @ 2400 rpm
Torque	398ft lb (540 Nm) @ 1600 rpm
Air cleaner	Centrifugal precleaner; dry type with safety element and restriction indicator
Oil filter	Full-flow/spin-on
Stroke	5 in (127 mm)
Bore	4.20 in (106 mm)
Compression ratio	19 to 1
Safety shutdown	Three-point automatic
Throttle control	Electronic

### ELECTRICAL SYSTEM

Voltage	12 V
Sweeper engine alternator	65 amp

### DUST SUPPRESSION SYSTEM

Type	High pressure/low volume
Capacity	250 gal (946 L)
Tank construction	Polyethylene filter; 200 mesh; cleanable
Fill diameter	2.5 in (63.5 mm)
Fill hose	25 ft (7620 mm)
Controls	Electric; in-cab

### Dust suppression system cont'd

Nozzles	2 on each broom; 5 around suction head; 2 inside suction nozzle; 2 on front axle; 4 inside hopper
Water level gauge	In-cab

### FAN SYSTEM

Type	Closed-face radial
Drive	Direct via 5 groove; banded power belt
Construction	Hardox steel
Balance	1.5 g on 2 sides
Diameter	32.75 in (832 mm)
Housing lining	Bolt-in corded rubber
Mounting	2 regreaseable sealed bearings
Vacuum enhancer	For heavy/light material; in-cab indicator

### PICKUP HEAD:

Type	Dual chambered full-width blast orifice
Operating direction	Forward and reverse
Suspension	Adjustable spring balanced
Length	90 in (2286 mm)
Pressure hose diameter	14 in (355.6 mm)
Suction hose diameter	14 in (355.6 mm)
Hose construction	3/8 in (9.5 mm) wire-reinforced molded rubber
Head area	3240 sq in (20 903 sq cm)
Controls	Hydraulic raise and lower
Skids	Double wide tungsten carbide
Construction	Abrasion-resistant steel inlet and outlet transitions.

### PAINT

One coat of sealer/primer and two coats of in standard white color.	
Paint	White; Sherwin Williams Genesis G2 #100268977

### SIDE BROOMS

Type	Vertical steel digger
Location	Right; left; forward of pickup head
Diameter	44 in (1118 mm)
Drive	Hydraulic
Suspension	Torque-sensing spring
Wear adjustment	Automatic

### Side brooms cont'd

Pressure	Manual
Speed	Variable; non-reversing
Segments	5 each side; disposable
Tilt angle adjustment	Manual with optional in-cab controls

### DEBRIS HOPPER

Volumetric capacity	6 cu yd (4.59 cu m)
Dump angle	50 degrees
Floor angle	0 degrees
Lifting	Twin hydraulic cylinders scissor-lift
Hopper dump door	Full height; full width open/close/lock hydraulically
Inspection doors	1 on left side of hopper
Dump height	24 in to 144 in high
Construction	Stainless steel floor; sides and roof

### HYDRAULIC SYSTEM

Type	Dual output 2 section
Pump capacity	8 gpm @ 1800 rpm (30 lpm) per section for 16 gpm total
Drive	Direct gear
Maximum pressure	2750 psi (190 bar)
Reservoir	25 gal (94 L)
Filter	10 micron; spin on
Protection	Pressure relief valve
Controls	Electro-hydraulic

### AUXILIARY HYDRAULIC SYSTEM

Type	Gear type; driven by electric motor
Function	Lower hopper; open/close hopper door; raise brooms and pickup head

### WARRANTY

All schwarze sweepers come with a standard one-year / 1200 hours parts & labor warranty with extended warranty options that provide the same warranty coverage as the standard warranty but extends the coverage from 2 up to 5 years.

*Note: Specifications are subject to change without notice.*

Sourcewell

Awarded Contract

Contract #093021-SWZ

**HGACBuy**  
THE SMART PURCHASING SOLUTION



© 2022 Schwarze Industries  
1055 Jordan Road  
Huntsville, AL 35811  
800.879.7933  
An Alamo-Group Company

