



AVAILABLE IN  
**ENGINE 1**  
SINGLE ENGINE CONFIGURATION

**PATENT  
PENDING**



# A7 Tornado SE™

The Schwarze A7 Tornado Single Engine is a heavy-duty, chassis mounted, single engine regenerative air street sweeper with an 8.4 cubic yard hopper. It follows over 20 years of successful operation throughout the United States and around the world of the A7 Tornado twin engine sweeper. The A7 Tornado is the most popular street sweeper in the Schwarze lineup, with its standard high flow saw tooth screens, high efficiency whisper wheel blower and proven blast orifice pickup head, the Schwarze A7 tornado is the standard of the sweeping industry.

The Schwarze A7 Tornado SE has no performance compromise from its twin engine version and can perform most typical sweeping at a low single engine speeds allowing for low noise and operational costs. When full power is needed for heavy jobs like construction and spring cleanup the A7 Tornado SE comes through with the same amount of sweep power available on the twin engine A7 Tornado.

Designed to operate exactly like the twin engine model, little if any additional operator and technician training is required. The Schwarze exclusive selectable "sweeps in reverse" feature allows unparalleled ability to clean all surfaces.



**PATENT PENDING SINGLE  
ENGINE TECHNOLOGY  
WITHOUT THE LOSS OF  
PERFORMANCE**

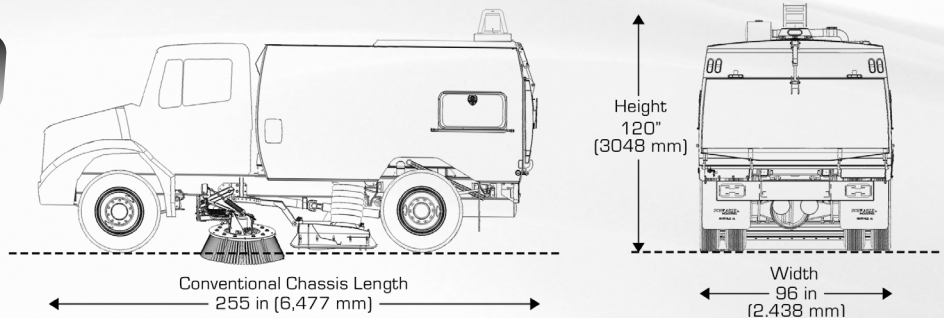

\*TYPICAL MEASUREMENTS SHOWN , EXACT DIMENSIONS DEPENDING ON OPTIONS AND TRUCK MANUFACTURER

### SWEEPING PATH

Pickup head only	90 in (2286 mm)
Head and 1 broom	117 in (2972 mm)
Head and 2 brooms	144 in (3658 mm)

### CHASSIS

Freightliner M2 106

### SWEEPER BODY

Construction	Welded 10-gauge stainless steel plate
Safety props	Lift spacers

### CHASSIS AND SWEEPER POWER

Model/type	ISB 6.7 in-line 6 cylinder
Emissions	GHG21 turbo-charged diesel

Manufacturer	Cummins Corp
Displacement	6.7 liter (409 c.i.)
Brake horsepower	240 hp (180 kw) @ 2500 rpm
Torque	560 ft. lb (759 Nm) @1100 rpm

Air cleaner	High capacity dry type with safety element and restriction indicator
Oil filter	Full-flow/spin-on
Stroke	5 in (127 mm)
Bore	4.20 in (106 mm)
Compression ratio	19 to 1
Safety shutdown	Cummins automatic
Throttle control	Electronic

### SWEEPER/CHASSIS ELECTRICAL

Voltage	12 V
Engine alternator	160 amp

### DUST CONTROL SYSTEM

Type	High pressure/low volume
Capacity	470 gallon (1786 L); options to 570 gallons (2166 liters)
Tank construction	Polyethylene
Pump Inlet filter	50 mesh; cleanable
Fill diameter	2.5 in (63.5 mm)
Fill hose	25 ft (7620 mm)
Controls	Electric; in-cab
Nozzles	2 on each broom; 5 around suction head; 2 inside suction nozzle; 2 on front axle; 2 inside hopper
Water level gauge	In-cab

### INSTRUMENTATION

Sweeper	Flat panel display; spray water level; hydraulic oil temperature: sweep mode; sweep in reverse; vacuum enhancer position; hopper position, sweeper diagnostics; sweep power; broom speed
---------	--

### FAN SYSTEM

Type	Closed-face radial
Drive	Hot shift PTO via 5 groove; banded power belt
Construction	AR steel
Balance	1.5 grams on 2 sides
Diameter	32.75 in (832 mm)
Housing lining	Bolt-in corded rubber
Mounting	2 regreasable sealed bearings
Vacuum enhancer	For heavy/light material; in-cab indicator

### PICKUP HEAD

Type	Dual chambered full-width blast orifice
Operating direction	Forward and reverse
Suspension	Adjustable spring balanced
Length	90 in (2286 mm)
Pressure hose diam	14 in (355.6 mm)
Suction hose diam	14 in (355.6 mm)
Hose construction	3/8 in (9.5 mm) wire-reinforced molded rubber
Head area	3240 sq in (20903 sq cm)
Controls	Hydraulic raise and lower
Skids	Double wide tungsten carbide
Construction	Abrasion-resistant steel inlet and outlet transitions.

### SIDE BROOMS

Type	Vertical steel digger
Location	Right; left; forward of pickup head
Diameter	44 in (1118 mm)
Drive	Hydraulic
Suspension	Torque-sensing spring
Wear adjustment	Automatic
Pressure	Manual
Speed	Variable; non-reversing
Segments	5 each side; disposable
Tilt angle adjustment	In-cab controls

### DEBRIS HOPPER

Volumetric capacity	8.4 cu yd (6.4 cu m)
Usable Capacity	7.0 cu yd (5.4 cu m)
Dump angle	51 degrees
Floor angle	3 degrees
Lifting	Twin hydraulic cylinders
Hopper dump door	Hydraulic open, close, lock
Inspection doors	1 on each side, pressure vessel lock
Hopper dump height	40 in (1016 mm)
Debris screens	Sawtooth drop down

### HYDRAULIC SYSTEM

Type	Variable displacement
Max Pump capacity	27 gpm @ 1800 rpm (103 lpm)
Drive	Belt
Maximum pressure	2750 psi (190 bar)
Reservoir	25 gal (94 L)
Filter	10 micron; in-tank with DP gauge
Protection	Pressure relief valve
Controls	Electro-hydraulic

### AUXILIARY HYDRAULIC SYSTEM

Type	Gear type; driven by electric motor
Function	Lower hopper; open/close hopper door; raise brooms and pickup head

### PAINT

One coat of sealer/primer and two coats of in standard white color.	
Paint	White; Sherwin Williams Genesis G2 #100268977

Note: Design and specifications subject to change without notice.



© 2022 Schwarze Industries  
1055 Jordan Road  
Huntsville, AL 35811  
800.879.7933  
An Alamo-Group Company