



A FAMILY COMPANY SINCE 1967

DULEVO 5000
EVOLUTION
INDUSTRIAL GRADE STREET SWEEPER

FIRST IN POWER CLEANING EQUIPMENT



SWEEPERLAND.COM



EQUIPMENT



PARTS



RENTALS



SERVICE



SUPPLIES

YOUR CLEANING SOLUTIONS RESOURCE™



Concept

The only sweeper in the world capable of combining maneuverability, economy, and reliability with a sweeping quality that is veritably superior. If you are looking for a sweeper that guarantees total control over particulates, maximum productivity and low costs of maintenance, the Dulevo 5000 sweeper will surely answer your needs. Designed for the sweeping of both urban and industrial environments, such as cement works, construction enterprises, fruit and vegetable markets, ports, airports, and any other environment, this sweeper guarantees an ecological and efficient performance.



F I R S T I N P O W E R C L E A N I N G E Q U I P M E N T



Dulevo combined system: InTHEORY

Thanks to the Dulevo patented mechanical-suction-filtering system, the Dulevo 5000 sweeper has a performance three times higher than any other traditional sweeper.

The collection is mechanical and is facilitated by the side brushes, which convey the debris toward the centre of the machine, where the cylindrical central brush then sends it at a high speed onto a vertical conveyer. The debris is loaded through the upper part in the refuse container, this way optimizing the loading capacity of the machine. The dust raised by the cylindrical central brush is sucked and kept in the refuse container thanks to the depression in the container itself created by two high-range and high-prevalence suction fans. The peculiar fabric filtering system retains even the thinnest particulates and completes the sweeping cycle, guaranteeing the reintroduction in the environment of clean air only.



Dulevo combined system: In PRACTICE

Thanks to the strong points and the advantages of the mechanical-suction-filtering combined collection system, the Dulevo 5000 is the ideal machine for the most diverse urban applications, in any climatic condition: Street sweeping in the summer time in the presence of sand and dust, disposal of autumn deposits of leaves and pine needles, refuse collection after local markets, and sweeping in the winter period at particularly harsh temperatures.

Indeed, only the side brushes (being located externally of the depression area) require a limited sprinkling of nebulized water for particulates control, allowing the sweeping with no need of water.





Quiet

In order to minimise noise during operation the highly efficient suction turbines have been kept as small as possible and are also positioned and shielded in such a way as to reduce the sound levels even further. But that's not all! The minimum possible noise level for operators and pedestrians have also been achieved by the use of sound-absorbent material and specific tests have been carried out to limit all possible sources of vibration.



Comfortable

Designed to ensure maximum levels of operator comfort the Dulevo 5000 cab also has simple and intuitive controls and excellent visibility. A comfortable, clean working environment is maintained within the cab by means of a pressurised filtered air system.

Double driving in the cabin

Even though the left-side driving accounts for only 34% of the world population, it is more and more frequent the need for a double driving option within the cabin; apart from the needs determined by the highway code, the double driving option in the cabin allows an easy driving during transfer, at the same time enabling a more accurate performance of cleaning operations, thanks to a better view of the roadside.

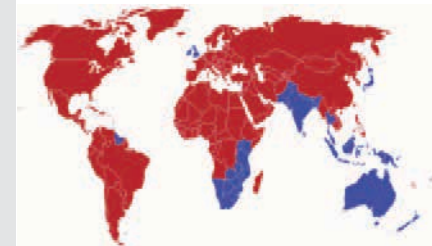



FABRIC FILTER & GORE® FILTER

The set of fabric pocket filters offers a wide filtering surface of more than 22 m², which allows long hours of operation without any obstruction risks.

The Dulevo filter, made with an imperishable fabric composed by a mixture of polyester (73%) and cotton (27%), is basically indestructible and allows a flawless filtering up to 3 micron.

On the other hand, if the filtering needs require higher levels, thanks to the exclusive collaboration with the Gore® group, Dulevo is today the only company at a global level capable of providing an exclusive range of Gore® fabric filters, which guarantee the total abatement of PM10, PM5, and PM2,5 particulates.

The extraordinary filtering GORE® materials considerably improve performance, guaranteeing:

- longer duration;
- Improved cleaning ease;
- Reduced maintenance;
- A 35% increase in air capacity.

Regardless of what will be your choice, the filtering group includes an efficient jolting device, which may be directly operated from the driving position. The filter jolting device, which is hydraulically controlled before the unloading phase, acts on the metallic bars that keep the filtering pockets in an outstretched position, vigorously shaking them in all directions in order to guarantee the total detachment of the particulates, which will then fall into the refuse container.

GORE dust filters installed in the industrial sweeper have 5 YEARS warranty.



Traditional filter



Dulevo filter



FILTERING CAPACITY (with Certificate of conformity issued by TÜV and DNV)



Fraction with granulometry < 1 µm	58%
Fraction with granulometry < 2,5 µm	92%
Fraction with granulometry < 5 µm	98%
Fraction with granulometry < 10 µm	>99%



Industry Line

Dulevo International appeals to the heavy industry market as well as mining sector as the only proven manufacturer of a dry sweeping system, thanks to its patented mechanical-suction collection system. Dulevos system benefits the end user by: Achieving a higher standard of plant cleanliness, Up to three times higher speed cleaning compared to any other sweeper on the market, a completely dry sweeping which permits a total reclaim of the picked up material, saving huge sums of time and money in labour costs and absolute adherence to modern environmental laws.



Airport Line

Dulevo International is addressing airport cleaning with a series of specific productions for heavy models expressly designed for cleaning airstrips, junctions and aprons, both in civil and military airports. Thanks to more than thirty years' experience in the field of industrial and urban cleaning and to a patented mechanical suction sweeping system, the Dulevo sweepers ensure: higher quality of cleaning, sweeping speed three times higher than any other machine currently present on the market, the unique method of dry-cleaning, with no water waste, huge savings in terms of time and money, a considerable lowering in maintenance costs for each vehicle a considerable saving in terms of overall costs compared to any other airport sweeper.



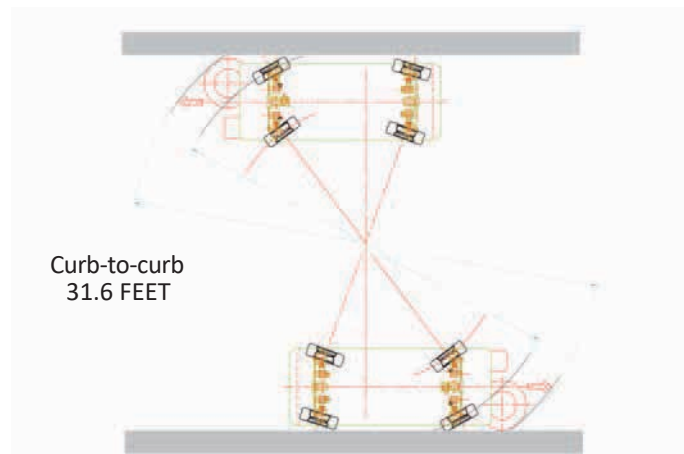
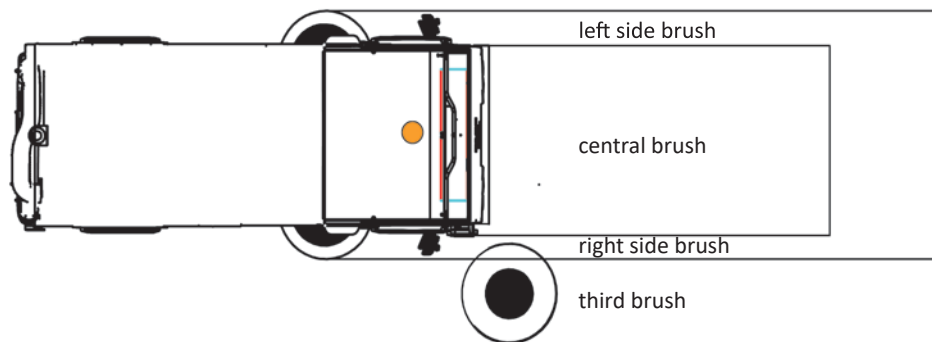

TECHNICAL DATA		5000
Sweeping width		
- With central brush	IN	51.18
- With side brushes	IN	102.4
- With third brush	IN	137.8
Waste container capacity	GAL	1,320.86
Dumping height	IN	45.27
Dumping height (opt)	IN	86.61
Seats in the cabin		2-3 (opt)
Cleaning performance	FT ² /H	1,130,210
Maximum speed	MPH	26
PM 10 filtration	%	99
Engine Brand		FPT Industrial (IVECO)
Fuel		DIESEL
Length (with 3 rd brush)	IN	204 (233)
Width	IN	92
Height	IN	112



 800.626.7835

 info@sweeperland.com

Bortek is a locally owned, family company and has been for over 50 years. We've done so with the proud tradition of putting our customers first. Our purpose is to consistently provide the best possible solutions and support to solve our customers' facilities maintenance, cleaning, and sanitation problems.

Each and every one of our over 16,000 customers is special with unique cleaning problems. At Bortek, our level of experience remains unmatched and allows us to create solutions that are tailored to your specific needs. Contact us today!



EQUIPMENT



PARTS



RENTALS



SERVICE



SUPPLIES

YOUR FACILITY SOLUTIONS RESOURCE™

SWEEPERLAND.COM



**INDUSTRIAL
GRADE™**

SERVICE & FULFILLMENT CENTERS

PENNSYLVANIA LOCATIONS

4713 & 4719 Gettysburg Rd | Mechanicsburg, PA 17055

105 North 16th St | Lebanon, PA 17046

11070 Parker Dr | North Huntingdon, PA 15642

1318 Bob Mellow Dr | Olyphant, PA 18434

NEW JERSEY LOCATIONS

2702 Cindel Dr, Unit 1 | Cinnaminson, NJ 08077

100 North 12th St | Kenilworth, NJ 07033

CONNECTICUT LOCATION

39A N Plains Industrial Rd | Wallingford, CT 06492

